

CONVECTION OVEN
(Model : CO- 42 / 81 / 150)**FORCED
CONVECTION OVEN**

Before operating this unit,
please read and understand
this manual completely and
keep it for future reference.

**HumanLab Instrument Co.**



Table of Contents

- 1 Features
- 2 Setup
- 3 Cautions
- 4 Description of the parts
- 5 Temperature Controls
- 6 Maintenance and Storage
- 7 Troubleshooting
- 8 Warranty
- 9 Technical Specifications

FORCED CONVECTION OVEN

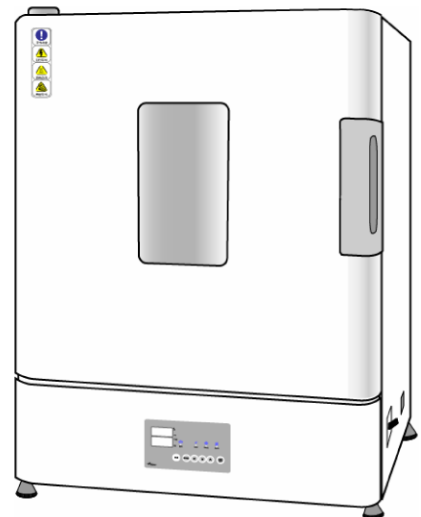
• Safety warnings













주의사항

Before operating, read and understand safety warnings thoroughly and use this equipment properly.

Keep these warnings in mind for your safety.

Safety Warnings: Danger!,Warning!,Caution!

-  **Danger** : Failure to observe this instruction can result in a personal injury or death.
-  **Warning** : Failure to observe this instruction may cause a fatal injury
-  **Caution** : Violation of this instruction and improper use may cause a serious injury and property damage.

 Do not contact	<p style="text-align: right;"> Caution</p> <p>Fire or heat injury may occur. Do not touch the exhaust port. Do not put objects near the exhaust port.</p>
 High Voltage	<p style="text-align: right;"> Warning</p> <p>Electric shock may occur. Unplug the power before you open the covers.</p>
 Explosion	<p style="text-align: right;"> Danger</p> <p>Explosion or fire may occur due to improper handling. Do not put flammable, explosive materials in the oven.</p>
 Electric Shock	<p style="text-align: right;"> Warning</p> <p>A risk of electric shock exists. Make sure to install a ground wire. Electric shock may occur without a ground wire installation.</p>

FORCED CONVECTION OVEN

1. Features

This equipment provides various research uses and applications regarding heating and drying process such as heat aging test, heat hardening test, and drying of test sample.

This product has following features for user's safety and convenience.

- 1) Specially designed low-noise and low-vibration fan motor.
- 2) The grounded circuit prevents a short circuit and overflow of electricity.
- 3) Accurate temperature controls by Digital PID controller
- 4) High temperature ceramic wool & glass wool optimize insulation and heat loss.
- 5) Threefold tempered safety glass windows for excellent insulation and easy observation
- 6) Set time/temperature function
- 7) Stable standing with uniquely designed leveling foot.

2. Setup

Caution

- Improper set up can cause a malfunction or an accident.

- 1) Install the equipment on a firm area avoiding heat, humidity, dust, and vibration.
- 2) Place it in a well-ventilated area with enough space.
- 3) Install it horizontally on a firm and stable surface.
- 4) The door can opens to an angle of 180 degree, please consider enough space.

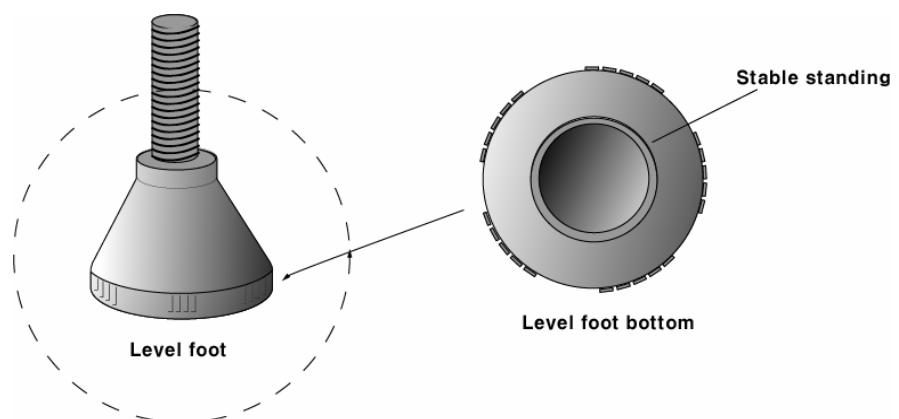

Confirm that the equipment is leveled by using of leveling feet.

FORCED CONVECTION OVEN

3. Cautions

Danger

- Do not put flammable, explosive materials in the chamber. Explosion or fire may occur due to improper handling.

Warning

- Do not place flammable materials near the equipment. Fire may occur.
- Do not touch the power cord with wet hands. Electric shock may occur.
- Do not plug too many equipment into the same electric outlet. Overload may cause a fire..
- Make sure to connect a ground wire. Electric shock may occur without a ground wire.

Caution

- Before plugging into the electric outlet, make sure that the power voltage is **220VAC, 50/60Hz**.
- Avoid using other electric equipment with high voltage current near this equipment.
- Do not pour water on this equipment directly.
A short circuit may occur. .
- Do not use acid solution, benzene, and sharp objects, to clean the equipment. It may cause changes of color or damage. Rubber and plastic parts are likely to change easily. Do not use any volatile material. If you use any detergent, clean it with water thoroughly
- Unplug from an outlet by holding the plug. Do not unplug it by pulling on the power cord.
- If this unit is not going to be used for a long period of time, remove the plug from an outlet.
- Damaged power cord can cause a short circuit or a fire.
- **Make sure to open the air exhaust port for natural convection and ventilation in the chamber.**
- Avoid putting too many objects in the chamber. It will block normal air circulation.
- Do not cover the shelves with **aluminum foil**. It may cause temperature control malfunction or an obstruction of air circulation.

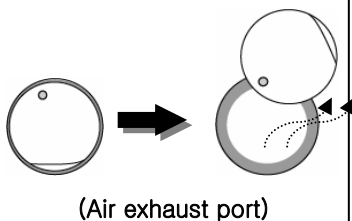

Aluminum foil



FORCED CONVECTION OVEN

4. Description of the parts

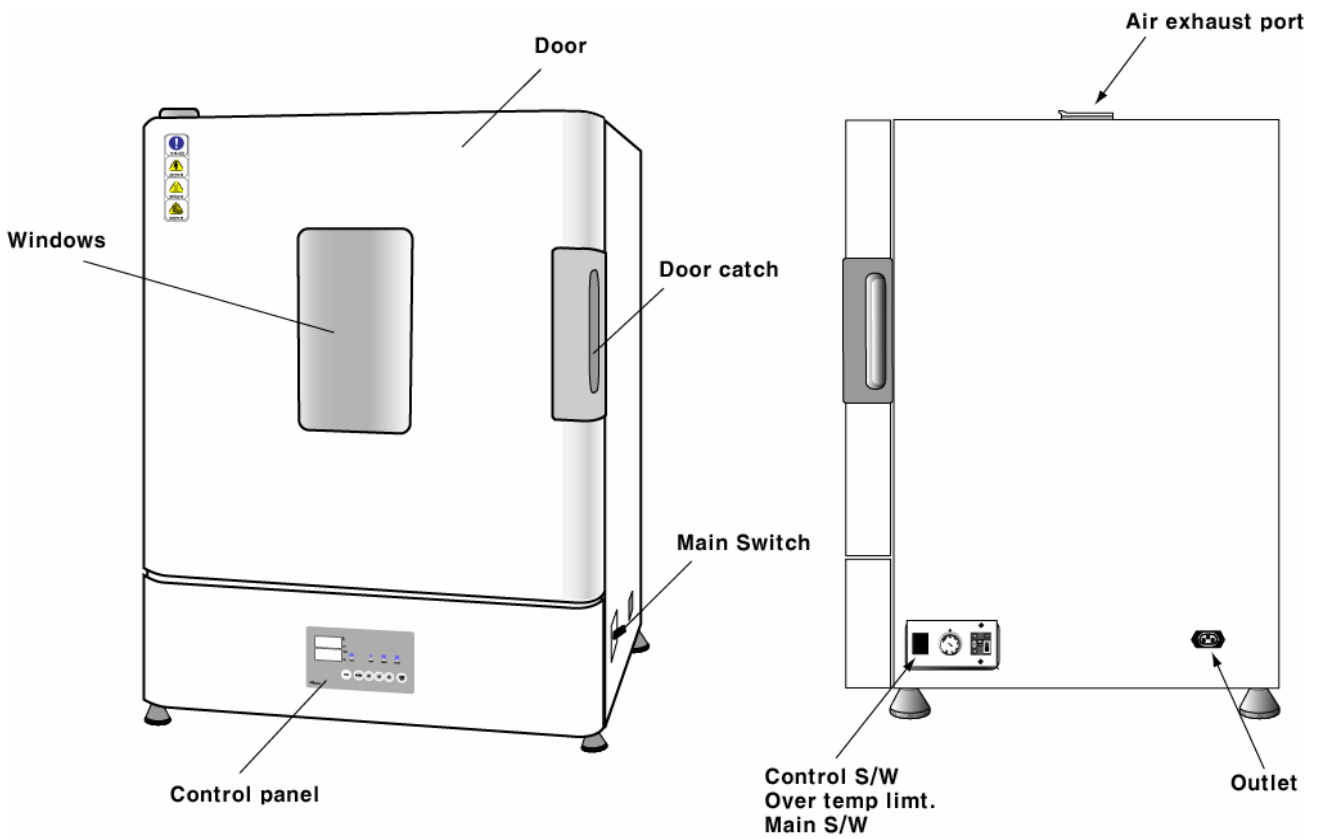

FORCED CONVECTION OVEN

FORCED CONVECTION OVEN

4. Description of the parts

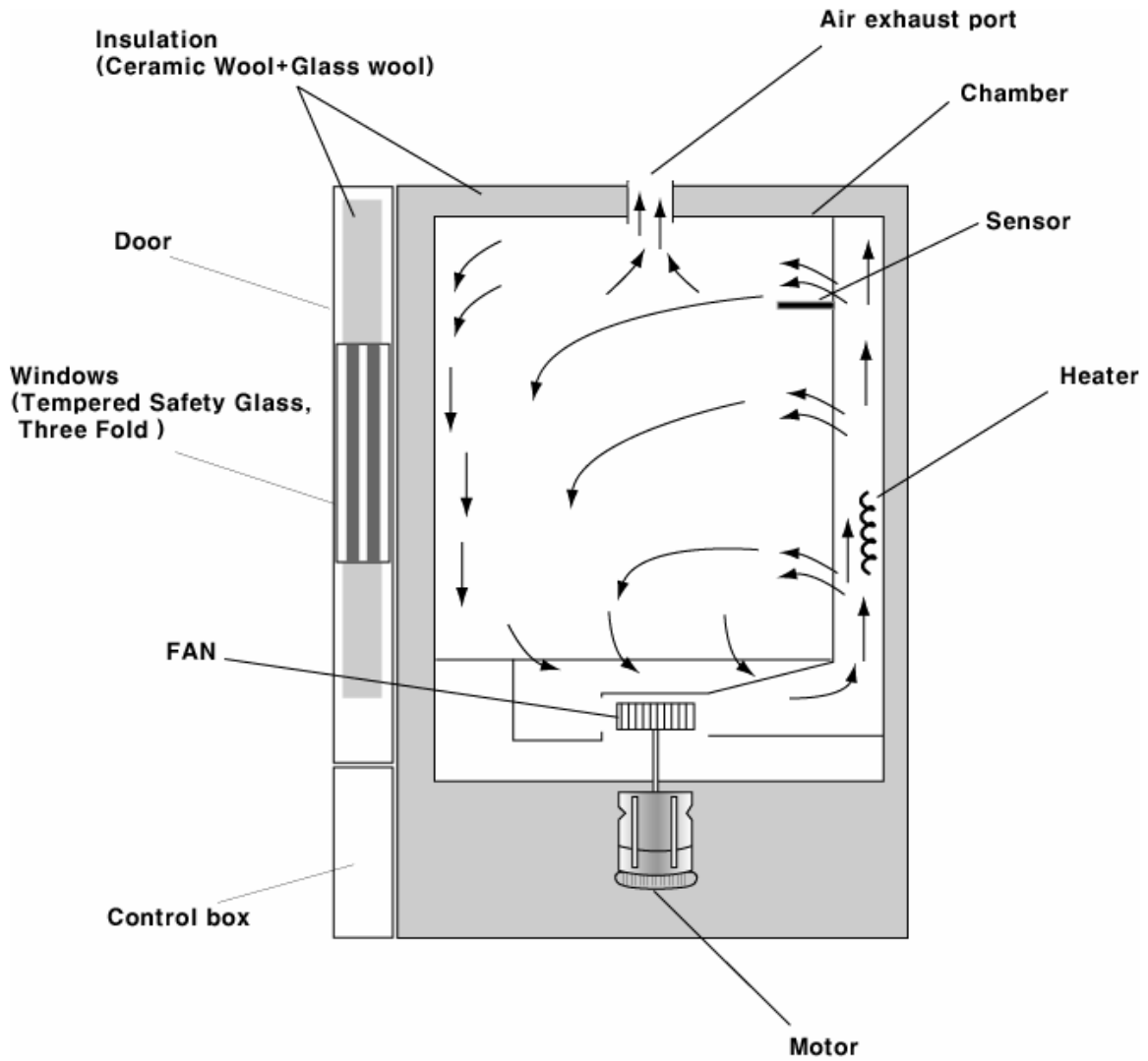

FORCED CONVECTION OVEN

FORCED CONVECTION OVEN

4. Description of the parts

 Caution

Default over temp format is 250 °C

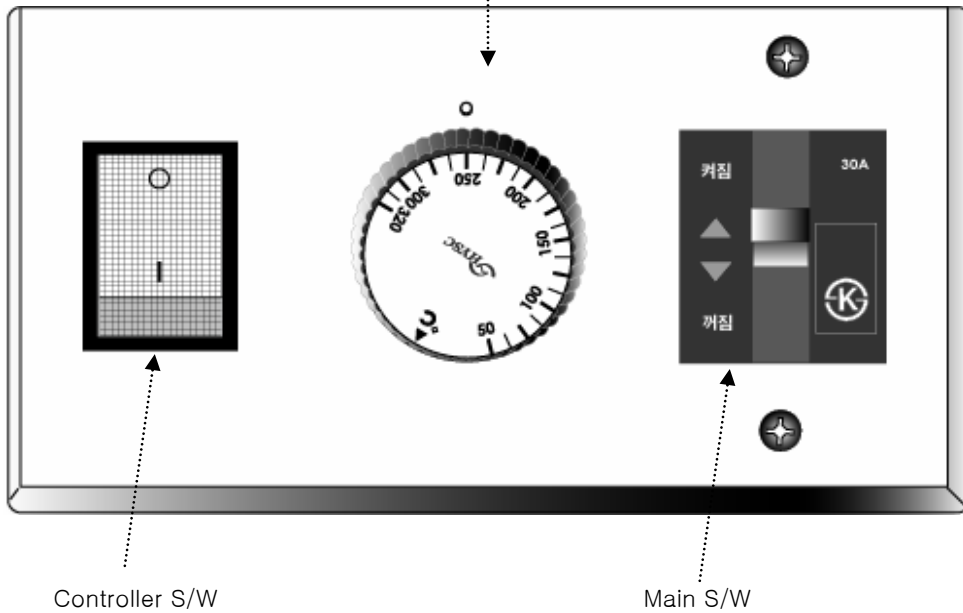

 Caution

If this system is not going to be used for a long period of time.
-. Remove the plug from an outlet.

FORCED CONVECTION OVEN

FORCED CONVECTION OVEN

5. Controls

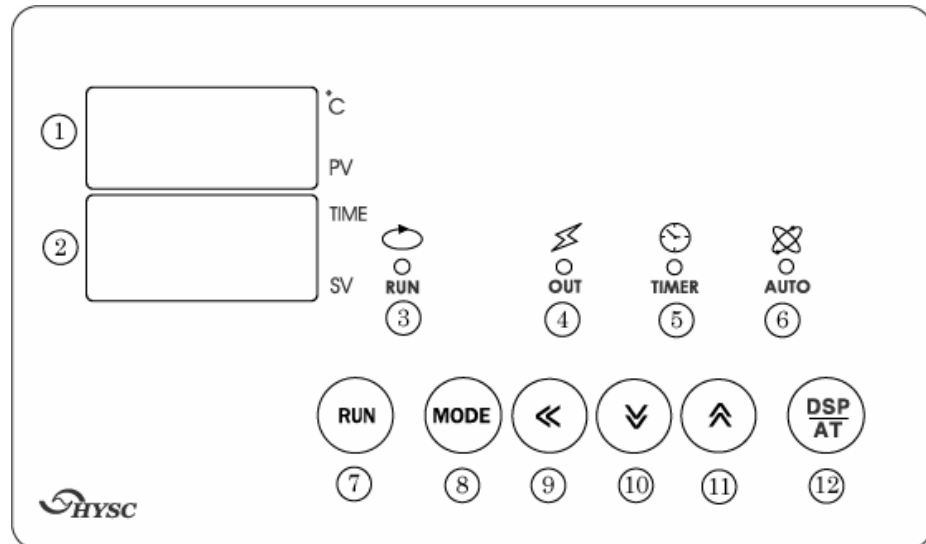

(1) Functions and Features of the control panel

- | | |
|--|------------------------------------|
| ① Displays actual oven temperature & each mode | ⑦ Start/Stop running key (RUN) |
| ② Displays set temperature & data of each mode | ⑧ Parameter setting key (MODE) |
| ③ Displays the system is running (START) | ⑨ Digit position movement key (<) |
| ④ Displays the heater is operating (OUT) | ⑩ Decrease value key (▽) |
| ⑤ Displays the timer is working (TIMER) | ⑪ Increase value key (△) |
| ⑥ Displays Auto Tuning is functioning.(AUTO) | ⑫ DSP Auto tuning key (AUTO) |

(2) Indicator lights



Will be lit when the system is running/ Turns off when it stops running



Will be lit when the heater is operating.



Begins flashing until set temperature is reached. After set temperature is reached, it will be lit. Turns off at the end of set time. (If timer set is 00:00, it will not be lit.)



Begins flashing during Auto tuning. Turns off at the end of Auto tuning. .

FORCED CONVECTION OVEN

(3) Operating Procedures

Start



Turn the power switch on.

The PV display shows the actual temperature in the oven.

The SV display shows set temperature.

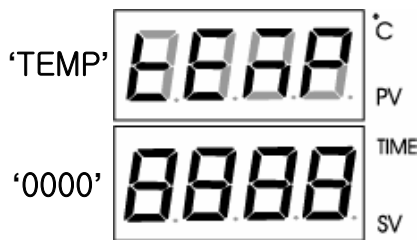

Press the "Mode" key ⑧ to enter temperature set mode. 'TEMP' appears in the PV display ①. Set temperature display (SV display②) begins flashing to set desired temperature.

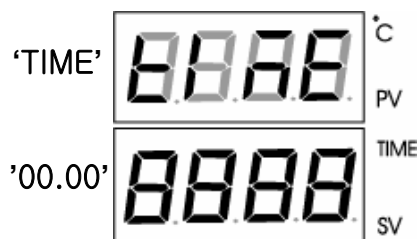

Press the "Mode" key ⑧ once again to enter timer mode. 'TIME' appears in the PV display ①. The SV display② begins flashing to set the timer.

Default time format is **Hour/ Minute(HH.MM)**. Other time formats are Date.Hour / Hour.Minute / Minute.Second (DD.HH/HH.MM/MM.SS)

FORCED CONVECTION OVEN

(3) Operating Procedures

Setup



Press the “Mode” key ⑧ to enter the temperature set mode. ‘TEMP’ appears in the PV display①. Set temperature display (SV display②) begins flashing to set desired temperature.



⑨ Press the “<” key to move to the next digit position.



Press the “up Δ ⑪” key to increase value.
Press the “down ∇ ⑩” key to decrease value.



Press the “Mode” key ⑧ to enter timer mode. ‘TIME’ appears in the PV display①. The SV display② begins flashing to set timer.



Set the timer as the same way of temperature set by using of the arrow keys. If timer set is **00:00**, the timer will not function. Only set temperature will operate.



Press the “Mode” key ⑧ to complete setting. The set value stops flashing. The displays return to PV/SV mode..

FORCED CONVECTION OVEN

(4) Operating Procedures & Function

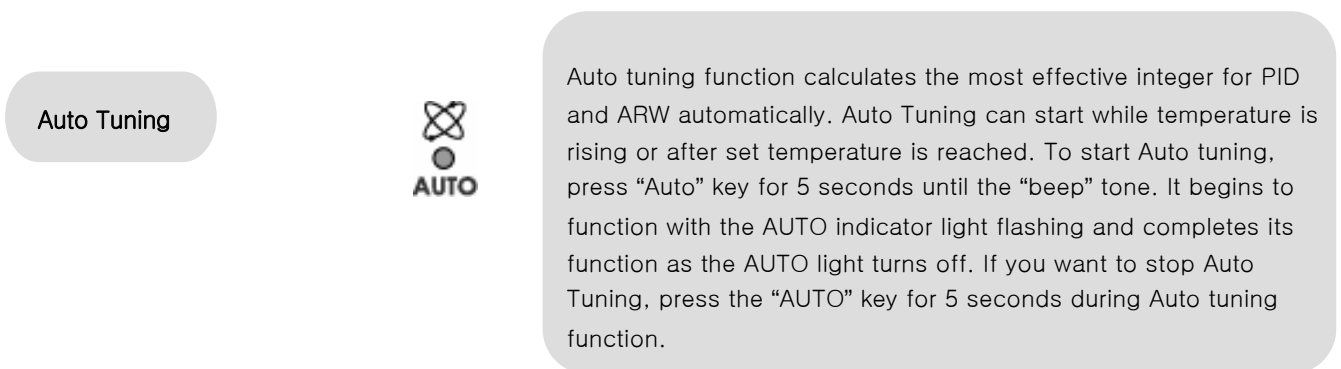
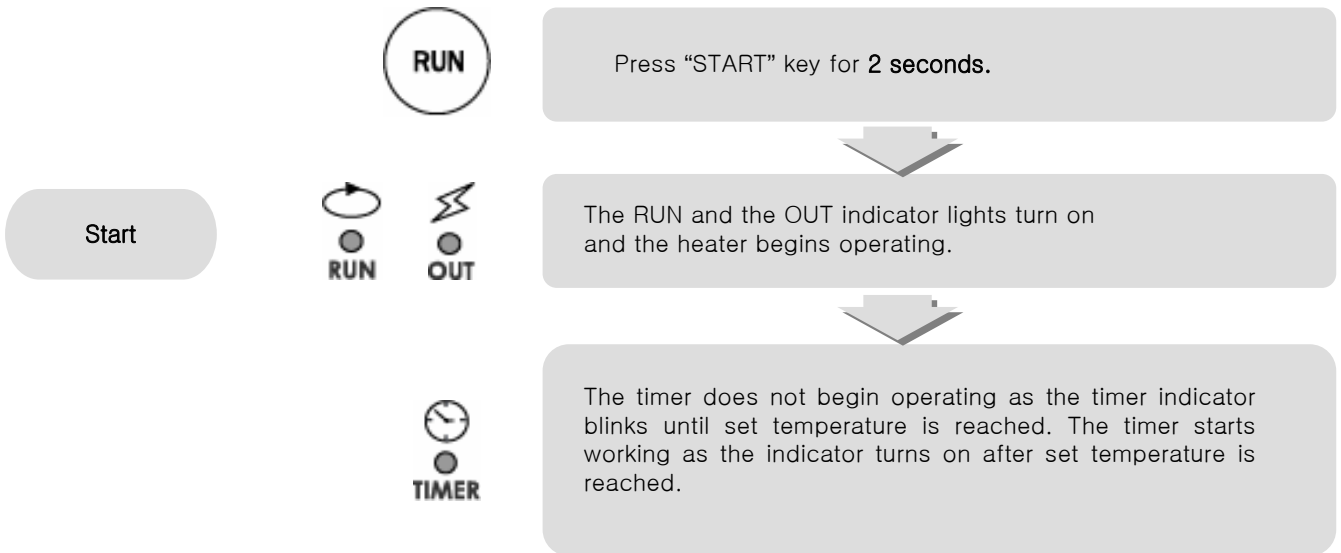

- Because Auto tuning has already been set from the factory, Auto tuning is not necessary. Use Auto tuning only if it is needed or if the operation is unstable.

FORCED CONVECTION OVEN

6. Maintenance and Storage

Warning

- Make sure to unplug the unit from an outlet before cleaning the unit to avoid an electric shock.

Caution

- Pull the plug when disconnecting from an outlet. Do not pull the power cord.
- Do not use acid solution, benzene, and sharp objects to clean the equipment. It may cause changes of color or damage of the equipment.

1) To clean the inside of the chamber.

- Remove the plug from an outlet.
- Remove the shelves and shelf hangers from the chamber.
- Wipe the inside with a soft cloth using a neutral detergent.
- Clean the inside once more with a soft towel.

2) To clean the surface of the equipment.

- Use a sponge or a soft cloth with a neutral detergent
- Wipe the unit with a dry cloth.
- Do not use organic solvent.

3) To clean the electric parts.

- Always use a dry cloth.

4) If this system is not going to be used for a long period of time.

- Remove the plug from an outlet.
- Clean the unit with a soft towel.
- Wrap and store it.

FORCED CONVECTION OVEN

7. Troubleshooting



Warning

- Switch off the unit before any maintenance and make sure to disconnect the power.
- If you are not authorized personnel, do not try to open, repair, or modify the unit. It can cause a fire or malfunction inflicting an injury upon people.

Symptom	Corrective Actions
The unit does not operate	<ul style="list-style-type: none">- . Make sure the power cord is plugged.- . Make sure the switch is on.- . Check a power outage.
Decrease of heating ability	<ul style="list-style-type: none">- . Check the heater
Temperature does not rise	<ul style="list-style-type: none">- . Check the set temperature- . Check the heater
Malfunctions of the controller	<ul style="list-style-type: none">- . Check whether other high voltage electric equipment is working nearby.

8. Warranty

- 1) We provide free repair service for this product against defects in material or workmanship for a period of one year, when it is used under appropriate conditions. Before requesting service, check the followings:
 - . Malfunctioned part and conditions (a detailed explanation is required)
 - . Model Number
 - . Purchased date* Customer will pay for the delivery charges of the product for repair service.
- 2) In case of followings, the repair service will be charged.
 - . Damage due to improper operation, modification, or unauthorized attempt to repair
 - . Damage due to inappropriate handling or transportation.
 - . Damage due to acts of God such as fire, flood, and wrong voltage supply.
 - . Damage due to not following operating instructions.
- 3) Contact authorized service center or your dealer for additional information.

FORCED CONVECTION OVEN

9. Specifications

Model		CO-81(H)	CO-150(H)	CO-300(H)	CO-630(H)
Capacity		81 liter	150 liter	300 liter	630 liter
Chamber (WxB xH)mm		450x400x450	600x500x500	600x500x1000	900x700x1000
Temp.	Range	Max. 250°C ±1°C / H series : Max. 350.°C ±1°C			
	Controller	Digital PID controller with PT 100 ohm sensor			
Timer		Digital / 99 hr , 59 min			
Heating	Output	1.6 Kw	2 Kw	2.5 Kw	3 Kw
	Time	15 min up to 100°C			
Blower		50W x1	50W x 1	60W x 1	1/4Hp x 1
Material	Interior	Stainelss steel			
	Exterior	Powder coated steel plate			
	Insulation	Ceramic fiber			
Door		Magnetic closure with silicon packing, Tempered safety glass inner window			
Shelves		Stainelss steel wire, adjustable			
Control & Display		Microprocessor digital PID control with LCD display			
Safety Device		Over temp. limiter			
Electric Power		220VAC,50/60Hz			
Overall (WxBxH)mm		620x575x870	770x675x920	760x640x1030	1160x740x1430
Weight (Kg)		70	95	130	220

Specifications are subject to change without notice.

FORCED CONVECTION OVEN

* Change of time format

Default time format is Hour / Minute(HH.MM).
You can change it with the following procedure.

1. Turn the power "On"
2. Press the "Mode" key for 2 seconds until the 'beep' sound.
(Entering Parameter Set mode)
3. Press the "Mode" key and the "<" key at the same time for 2 seconds until 'beep' sound.(Entering Main Menu of Factory Mode).



4. After P.SYS displayed, Press the "Mode" key continuously until TM.SC(time format set) displays.
5. Use the "Up/ Down" arrow keys to set time format (TM.SC).
HH.MM(Hour.Minute)/DD.HH(Date/Hour)/MM.SS(Minute.Second)

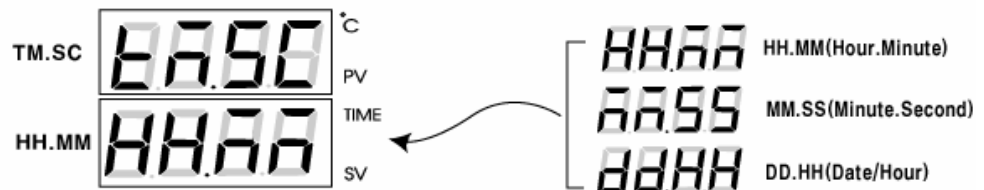

6. Press the "Mode" key to store the input.
(LED stops flashing after input completed)
7. Press the "Mode" and the "<" keys at the same time for 2 seconds to exit to the initial stage.

FORCED CONVECTION OVEN

* storing the factory default setting

To restore the default setting from system memory, follow the procedure.
Use it only when set values get too complicated.

1. Turn the power on
2. Press the "Mode" key for 2 seconds until the 'beep' sound.
(Entering Parameter Set mode)
3. Press the "Mode" key to display 'LOC'.



4. Change to '1000' by using of the "Left / Down" arrow keys and press the "Mode" key once to complete the input. (LED stops flashing after input completed)



5. Press the "Mode" key to change to 'LOAD' display.
Use the arrow keys to change 'NO' to "YES" and Press the "Mode" key once to complete the input. (LED stops flashing after input completed)

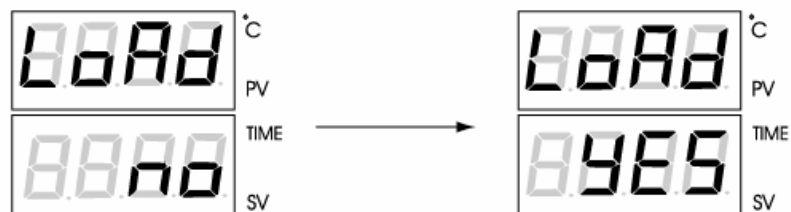

6. Press the "Mode" and the "<" keys at the same time for 2 seconds to exit to the initial stage.

FORCED CONVECTION OVEN

* 7 Segment Display Examples

A	B	C	D	E	F	G	H	I	J	K	L
M	N	O	P	Q	R	S	T	U	V	W	X
Y	Z	0	1	2	3	4	5	6	7	8	9



HumanLab Instrument Co.

B-401, Jaeun Bldg, #417-33,
Younghwa-dong, Jangan-gu,
Suwon-si 440821, Korea

Tel : +82-31-256 3403
Fax : +82-31-256 3404
Email : sales@humanlab.co.kr
www.humanlab.co.kr



Made in Korea